



Revolution Products

# Park Avenue Library Furniture 2010 Price List



Revolution Products  
109 White Oak Road, Bldg. C1  
Greenville, SC 29609  
800-241-9810 / Fax: 800-241-9827

# Park Avenue

Welcome to Park Avenue from Revolution Products.

## Index

---

I.	Terms and Conditions	
II.	<b>Park Avenue</b> Reading Tables with square tapered legs	Pgs. 3-4
III.	<b>Park Avenue</b> IT Tables with monitor racks with square tapered legs	Pg. 5
IV.	<b>Park Avenue</b> IT Tables with Sentinel end frame, monitor racks and square tapered legs	Pgs. 6-7
IV.	<b>Park Avenue</b> Tables with Sentinel end frame and square tapered legs	Pg. 8-9
V.	<b>Park Avenue</b> Post and Panel Carrels with square tapered legs	Pgs. 10-11
VI.	<b>Park Avenue</b> Full Panel Carrels with square tapered legs	Pgs. 12-13
VII.	<b>Park Avenue</b> Reading Tables with round tapered legs	Pgs. 14-15
VIII.	<b>Park Avenue</b> IT Tables with monitor racks with round tapered legs	Pg. 16
IX.	<b>Park Avenue</b> Post and Panel Carrels with round tapered legs	Pgs. 17-18
X.	<b>Park Avenue</b> Full Panel Carrels with round tapered legs	Pgs. 19-20
XI.	<b>Park Avenue</b> End Panels	Pgs. 21-25
XI.	<b>Park Avenue</b> Product Drawings	Pgs. 26-28



# Park Avenue

**Terms of Sale:** All prices are FOB Greenville, SC. Net 30 days from date of shipment. All prices are list and subject to change without notice. Interest of 2% per month will be assessed on past due invoices. Possession of price list does not constitute authority to purchase or sell products herein.

**Taxes:** All applicable taxes are extra. If a client is tax exempt please provide tax certificate.

**Ordering:** Orders must have all pertinent information provided before they will be processed and entered including model numbers, quantities and finish, laminate and fabric selections where appropriate. Please provide a requested by date, or not to ship before date on your order.

**Warranty:** All items are warranted for 10 years unless otherwise stated. Warranty is for initial purchaser and only valid as long as the product is owned by original customer. The warranty, which begins at date of manufacture, covers defects in materials and workmanship found during the normal usage of product during the warranty period. Revolution Products will at it's option repair or replace the defective product with a comparable component or product. Warranty does not cover any "Customers Own Material" used in manufacture. Except as stated above, Revolution Products makes no express or implied warranties as to any product and in particular makes no warranty of fitness for any particular use. At Revolution Products option, product repair, or replacement is the customer's exclusive remedy for any and all product defects.

**BIFMA and ANSI Testing:** All products offered by Revolution Products meet or exceed applicable BIFMA and ANSI testing standards.

**New Accounts:** New Accounts can only be established with the approval of a Revolution Products representative. New accounts will be subject to special credit reference requirements and deposit terms before they are approved.



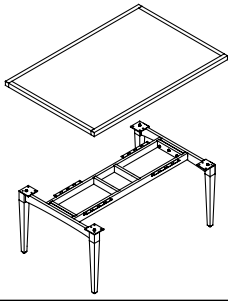

# Park Avenue

## READING TABLES WITH SQUARE TAPERED LEGS

MODEL NUMBER	DESCRIPTION	LIST PRICE
PS-3648-O-T	Table 36" deep x 48" wide in oak, HPL top 1 1/4" thick with 1 3/4" W X 1 5/8" H drop edge banding, 3" arched aprons at the ends, 2 3/4" solid oak square legs tapered to 1 1/2" at the bottom, metal leg plates, and ladder keel for structural support	2280.00
PS-3060-O-T	Table 30" deep x 60" wide in oak, HPL top 1 1/4" thick with 1 3/4" W x 1 5/8" H drop edge banding, 3" arched aprons at the ends, 2 3/4" solid oak square legs tapered to 1 1/2" at the bottom, metal leg plates, and ladder keel for structural support	2433.00
PS-3660-O-T	Table 36" deep x 60" wide in oak, HPL top 1 1/4" thick with 1 3/4" W x 1 5/8" H drop edge banding, 3" arched aprons at the ends, 2 3/4" solid oak square legs tapered to 1 1/2" at the bottom, metal leg plates, and ladder keel for structural support	2493.00
PS-3672-O-T	Table 36" deep x 72" wide in oak, HPL top 1 1/4" thick with 1 3/4" W x 1 5/8" H drop edge banding, 3" arched aprons at the ends, 2 3/4" solid oak square legs tapered to 1 1/2" at the bottom, metal leg plates, and ladder keel for structural support	2726.00
PS-3696-O-T	Table 36" deep x 96" wide in oak, HPL top 1 1/4" thick with 1 3/4" W x 1 5/8" H drop edge banding, 3" arched aprons at the ends, 2 3/4" solid oak square legs tapered to 1 1/2" at the bottom, metal leg plates, and ladder keel for structural support	3134.00
PS-4272-O-T	Table 42" deep x 72" wide in oak, HPL top 1 1/4" thick with 1 3/4" W x 1 5/8" H drop edge banding, 3" arched aprons at the ends, 2 3/4" solid oak square legs tapered to 1 1/2" at the bottom, metal leg plates, and ladder keel for structural support	2827.00
PS-4296-O-T	Table 42" deep x 96" wide in oak, HPL top 1 1/4" thick with 1 3/4" W x 1 5/8" H drop edge banding, 3" arched aprons at the ends, 2 3/4" solid oak square legs tapered to 1 1/2" at the bottom, metal leg plates, and ladder keel for structural support	3260.00
PS-4872-O-T	Table 48" deep x 72" wide in oak, HPL top 1 1/4" thick with 1 3/4" W x 1 5/8" H drop edge banding, 3" arched aprons at the ends, 2 3/4" solid oak square legs tapered to 1 1/2" at the bottom, metal leg plates, and ladder keel for structural support	2929.00
PS-4896-O-T	Table 48" deep x 96" wide in oak, HPL top 1 1/4" thick with 1 3/4" W x 1 5/8" H drop edge banding, 3" arched aprons at the ends, 2 3/4" solid oak square legs tapered to 1 1/2" at the bottom, metal leg plates, and ladder keel for structural support	3352.00



# Park Avenue

## READING TABLES WITH SQUARE TAPERED LEGS

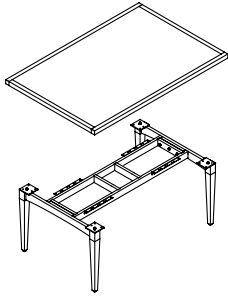

MODEL NUMBER	DESCRIPTION	LIST PRICE
PS-4242-O-T	Table 42" square in oak, HPL top 1 1/4" thick with 3/4" W x 1 5/8" H oak drop edge banding, 3" arched aprons on 2 ends, 2 3/4" solid oak square legs tapered to 1 1/2" at the bottom with metal leg plates, ladder keel for structural support	2131.00
PS-4848-O-T	Table 48" square in oak, HPL top 1 1/4" thick with 3/4" W x 1 5/8" H oak drop edge banding, 3" arched aprons, 2 3/4" solid oak square legs tapered to 1 1/2" at the bottom with metal leg plates, ladder keel for structural support	2160.00
PS-42R-O-T	Table 42" round in oak, HPL top 1 1/4" thick with 3/4" W x 1 5/8" H oak drop edge banding, 3" arched aprons, 2 3/4" solid oak square legs tapered to 1 1/2" at the bottom with metal leg plates	2423.00
PS-48R-O-T	Table 48" round in oak, HPL top 1 1/4" thick with 3/4" W x 1 5/8" H oak drop edge banding, 3" arched aprons, 2 3/4" solid oak square legs tapered to 1 1/2" at the bottom with metal leg plates	2648.00
PS-60R-O-T	Table 60" round in oak, HPL top 1 1/4" thick with 3/4" W x 1 5/8" H oak drop edge banding 3" arched aprons, 2 3/4" solid oak square legs tapered to 1 1/2" at the bottom with metal leg plates	2853.00
SUFFIX -M	For maple change the suffix O to M and add 7 percent.	
SUFFIX -C	For cherry change the suffix O to C and add 20 percent.	



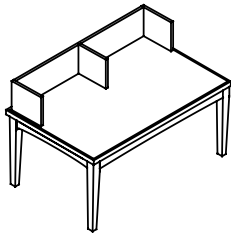

# Park Avenue

## IT TABLES WITH MONITOR RACKS AND SQUARE TAPERED LEGS

MODEL NUMBER	DESCRIPTION	LIST PRICE
PS-3036-O-IT	Information technology table 30" deep x 36" wide in oak, HPL top 1 1/4" T with 1 3/4" W x 1 5/8" H drop edge banding, 3" arched aprons at the ends, 2 3/4" solid oak square legs tapered to 1 1/2" at the bottom, metal leg plates and ladder keel, 10" high monitor rack at the back of the table and extending forward 10" at each end	2474.00
PS-3048-O-IT	Information technology table 30" deep x 48" wide in oak, HPL top 1 1/4" T with 1 3/4" W x 1 5/8" H drop edge banding, 3" arched aprons at the ends, 2 3/4" solid oak square legs tapered to 1 1/2" at the bottom, metal leg plates and ladder keel, 10" high monitor rack at the back of the table and extending forward 10" at each end	2567.00
PS-3060-O-IT	Information technology table 30" deep x 60" wide in oak, HPL top 1 1/4" T with 1 3/4" W x 1 5/8" H drop edge banding, 3" arched aprons at the ends, 2 3/4" solid oak square legs tapered to 1 1/2" at the bottom, metal leg plates and ladder keel, 10" high monitor rack at the back of the table and extending forward 10" at each end	2777.00
PS-3072-O-IT	Information technology table 30" deep x 72" wide in oak, HPL top 1 1/4" T with 1 3/4" W x 1 5/8" H drop edge banding, 3" arched aprons at the ends, 2 3/4" solid oak square legs tapered to 1 1/2" at the bottom, metal leg plates and ladder keel, 10" high monitor rack at the back of the table and extending forward 10" at each end	2829.00
PS-3072-O-IT2	Information technology table 30" deep x 72" wide in oak, HPL top 1 1/4" T with 1 3/4" W x 1 5/8" H drop edge banding, 3" arched aprons at the ends, 2 3/4" solid oak square legs tapered to 1 1/2" at the bottom, metal leg plates and ladder keel, 10" high monitor rack at the back of the table and extending forward 10" at each end and the center point dividing the unit intop 2 work spaces	3094.00
PS-3096-O-IT2	Information technology table 30" deep x 96" wide in oak, HPL top 1 1/4" T with 1 3/4" W x 1 5/8" H drop edge banding, 3" arched aprons at the ends, 2 3/4" solid oak square legs tapered to 1 1/2" at the bottom, metal leg plates and ladder keel, 10" high monitor rack at the back of the table and extending forward 10" at each end and the center point dividing the unit intop 2 work spaces	3583.00
PS-3096-O-IT3	Information technology table 30" deep x 96" wide in oak, HPL top 1 1/4" T with 1 3/4" W x 1 5/8" H drop edge banding, 3" arched aprons at the ends, 2 3/4" solid oak square legs tapered to 1 1/2" at the bottom, metal leg plates and ladder keel, 10" high monitor rack at the back of the table and extending forward 10" at each end and 2 center points dividing the unit intop 3 work spaces	3636.00





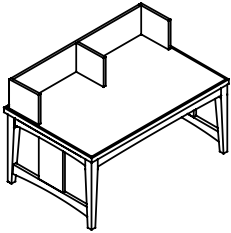

# Park Avenue

IT TABLES WITH MONITOR RACKS,  
SENTINEL ENDS AND SQUARE  
TAPERED LEGS

MODEL NUMBER	DESCRIPTION	LIST PRICE
PS-3096-O-ITS2	Information technology table 30" deep x 96" wide in oak, HPL top 1 1/4" T with 1 3/4" W x 1 5/8" H drop edge banding, Sentinel ends consisting of a 3" high arched apron, a 3" high arched stretcher, a solid vertical panel and 2 slats, 2 3/4" solid oak square legs tapered to 1 1/2" at the bottom with metal plates, ladder keel, 10" high monitor rack at the back of the table and extending forward 10" at each end and the center	4992.00
PS-3096-O-ITS3	Information technology table 30" deep x 96" wide in oak, HPL top 1 1/4" T with 1 3/4" W x 1 5/8" H drop edge banding, Sentinel ends consisting of a 3" high arched apron, a 3" high arched stretcher, a solid vertical panel and 2 slats, 2 3/4" solid oak square legs tapered to 1 1/2" at the bottom with metal plates, ladder keel, 10" high monitor rack at the back of the table and extending forward 10" at each end and 2 center points dividing the table into 3 equal work spaces	5045.00



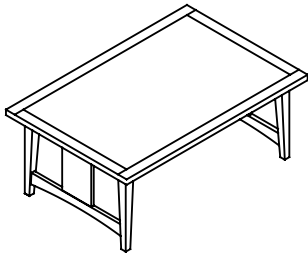

# Park Avenue

## TABLES WITH SENTINEL ENDS FRAME AND SQUARE TAPERED LEGS

MODEL NUMBER	DESCRIPTION	LIST PRICE
PS-3648-O-TS	Table 36" deep x 48" wide in oak, HPL top 1 1/4" thick with 1 3/4" W x 1 5/8" T drop edge banding, Sentinel ends consisting of a 3" high arched apron, a 3" high arched stretcher, a solid vertical panel and 2 slats, 2 3/4" solid oak square legs tapered to 1 1/2" at the bottom with metal leg plates, ladder keel for structural support	3023.00
PS-3060-O-TS	Table 30" deep x 60" wide in oak, HPL top 1 1/4" thick with 1 3/4" W x 1 5/8" T drop edge banding, Sentinel ends consisting of a 3" high arched apron, a 3" high arched stretcher, a solid vertical panel and 2 slats, 2 3/4" solid oak square legs tapered to 1 1/2" at the bottom with metal leg plates, ladder keel for structural support	3061.00
PS-3660-O-TS	Table 36" deep x 60" wide in oak, HPL top 1 1/4" thick with 1 3/4" W x 1 5/8" H drop edge banding, Sentinel ends consisting of a 3" high arched apron, a 3" high arched stretcher, a solid vertical panel and 2 slats, 2 3/4" solid oak square legs tapered to 1 1/2" at the bottom with metal leg plates, ladder keel for structural support	3286.00
PS-3672-O-TS	Table 36" deep x 72" wide in oak, HPL top 1 1/4" thick with 1 3/4" W x 1 5/8" H drop edge banding, Sentinel ends consisting of a 3" high arched apron, a 3" high arched stretcher, a solid vertical panel and 2 slats, 2 3/4" solid oak square legs tapered to 1 1/2" at the bottom with metal leg plates, ladder keel for structural support	3450.00
PS-3696-O-TS	Table 36" deep x 96" wide in oak, HPL top 1 1/4" thick with 1 3/4" W x 1 5/8" H drop edge banding, Sentinel ends consisting of a 3" high arched apron, a 3" high arched stretcher, a solid vertical panel and 2 slats, 2 3/4" solid oak square legs tapered to 1 1/2" at the bottom with metal leg plates, ladder keel for structural support	3796.00
PS-4272-O-TS	Table 42" deep x 72" wide in oak, HPL top 1 1/4" thick with 1 3/4" W x 1 5/8" H drop edge banding, Sentinel ends consisting of a 3" high arched apron, a 3" high arched stretcher, a solid vertical panel and 2 slats, 2 3/4" solid oak square legs tapered to 1 1/2" at the bottom with metal leg plates, ladder keel for structural support	3594.00
PS-4296-O-TS	Table 42" deep x 96" wide in oak, HPL top 1 1/4" thick with 1 3/4" W x 1 5/8" H drop edge banding, Sentinel ends consisting of a 3" high arched apron, a 3" high arched stretcher, a solid vertical panel and 2 slats, 2 3/4" solid oak square legs tapered to 1 1/2" at the bottom with metal leg plates, ladder keel for structural support	3940.00



# Park Avenue

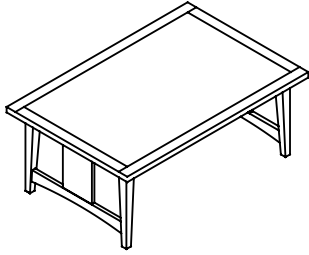

## TABLES WITH SENTINEL ENDS FRAME AND SQUARE TAPERED LEGS

PS-4872-O-TS	Table 48" deep x 72" wide in oak, HPL top 1 1/4" thick with 1 3/4" W x 1 5/8" H drop edge banding, Sentinel ends consisting of a 3" high arched apron, a 3" high arched stretcher, a solid vertical panel and 2 slats, 2 3/4" solid oak square legs tapered to 1 1/2" at the bottom with metal leg plates, ladder keel for structural support	3899.00
PS-4896-O-TS	Table 48" deep x 96" wide in oak, HPL top 1 1/4" thick with 1 3/4" W x 1 5/8" H drop edge banding, Sentinel ends consisting of a 3" high arched apron, a 3" high arched stretcher, a solid vertical panel and 2 slats, 2 3/4" solid oak square legs tapered to 1 1/2" at the bottom with metal leg plates, ladder keel for structural support	4328.00



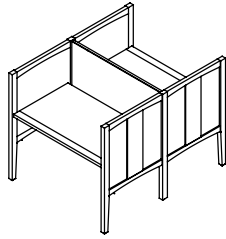

# Park Avenue

## POST AND PANEL CARRELS WITH SQUARE TAPERED LEGS

MODEL NUMBER	DESCRIPTION	LIST PRICE
PS-3136-O-PPSC	Elevated Panel Carrel work station starter in oak 31" deep x 38" wide x 48" high, 1 1/8" thick end panels with 2 1/2" high solid oak arched edge banding at the top and bottom of the panels with 5" wide center slat, 2" wide flat posts tapered on 2 sides from the bottom of the panel to 1 1/2" at the floor, 1 1/4" thick HPL work surface with 1 3/4" W oak edge banding	2593.00
PS-3136-O-PPSCA	Carrel work station adder in oak 31" deep x 36 1/2" wide x 48" high, 1 1/8" thick intermediate panel with arched detailing at the top and bottom of the panel, 2" wide flat posts tapered on 2 sides from the bottom of the panel to 1 1/2" at the floor, 1 1/4" thick HPL work surface with 1 3/4" thick edge oak banding	2021.00
PSD-3150-O-PPSC	Elevated Panel Carrel work station starter in oak 31" deep x 50" wide x 48" high, 1 1/8" thick end panels with 2 1/2" high solid oak arched edge banding at the top and bottom of the panel with 5" wide center slat, 2" wide flat posts tapered on 2 sides from the bottom of the panel to 1 1/2" at the floor, 1 1/4" thick HPL work surface with 1 3/4" W oak edge banding	2983.00
PS-3148-O-PPSCA	Carrel work station adder in oak 31" deep x 48 1/2" wide x 48" high, 1 1/8" thick intermediate panel with arched detailing at the top and bottom of the panel, 2" wide flat posts tapered on 2 sides from the bottom of the panel to 1 1/2" at the floor, 1 1/4" thick HPL work surface with 1 3/4" thick edge oak banding	2411.00
PS-3136-O-PPDF	Elevated Panel Carrel work station, double faced, starter in oak 61" deep x 38" wide x 48" high, 1 1/8" thick end panels with 2 1/2" high solid oak arched edge banding at top and bottom of panels with 5" wide center slat, 2" wide flat posts tapered on 2 sides from the bottom of the panel to 1 1/2" at the floor, 2 each 1 1/4" thick HPL work surfaces with 1 3/4" thick edge banding	4334.00
PS-3136-O-PPDFA	Carrel work station, double faced, adder in oak 61" deep x 36 1/2" wide x 48" high, 1 1/8" thick intermediate panels with arched detailing at the top and bottom of the panel, 2" wide flat posts tapered on 2 sides from the bottom of the panel to 1 1/2" at the floor, 2 each 1 1/4" thick HPL work surface with 1 3/4" thick oak edge banding	3413.00



# Park Avenue

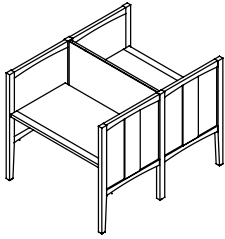

## POST AND PANEL CARRELS WITH SQUARE TAPERED LEGS

MODEL NUMBER	DESCRIPTION	LIST PRICE
PS-3148-O-PPDF	Elevated Panel Carrel work station, double faced, starter in oak 61" deep x 50" wide x 48" high, 1 1/8" thick end panels with 2 1/2" high solid oak arched edge banding at top and bottom of panels with 5" wide center slat, 2" wide flat posts tapered on 2 sides from the bottom of the panel to 1 1/2" at the floor, 2 each 1 1/4" thick HPL work surfaces with 1 3/4" thick edge banding	4886.00
PS-3148-O-PPDFA	Carrel work station, double faced, adder in oak 61" deep x 48 1/2" wide x 48" high, 1 1/8" thick intermediate panels with arched detailing at the top and bottom of the panels, 2" wide flat posts tapered on 2 sides from the bottom of the panel to 1 1/2" at the floor, 2 each 1 1/4" thick HPL work surface with 1 3/4" thick oak edge banding	3762.00
SHELF	For each book shelf at 145.00.	
SUFFIX -M	For maple change the suffix O to M and add 7 percent.	
SUFFIX -C	For cherry change the suffix O to C and add 20 percent.	



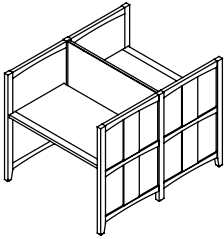

# Park Avenue

## FULL PANEL CARRELS WITH SQUARE TAPERED LEGS

MODEL NUMBER	DESCRIPTION	LIST PRICE
PS-3136-O-FPSC	Elevated Panel Carrel work station starter in oak 31" deep x 38" wide x 48" high, 1 1/8" thick end panels with 2 1/2" high solid oak arched edge banding at the top and bottom of the end panels with horizontal center slat and 5" wide vertical slats, 2" flat end posts tapered on 2 sides from the bottom of the panel to 1 1/2" at the floor, 1 1/4" thick HPL work surface with 1 3/4" wide oak edge banding	2908.00
PS-3136-O-FPSCA	Carrel work station adder in oak 31" deep x 36 1/2" wide x 48" high, 1 1/8" thick intermediate panel with arched detailing at the top and bottom of the panel, 2" flat end posts tapered on 2 sides from the bottom of the panel to 1 1/2" at the floor, 1 1/4" thick HPL work surface with 1 3/4" thick oak edge banding	2326.00
PS-3150-O-FPSC	Elevated Panel Carrel work station starter in oak 31" deep x 50" wide x 48" high, 1 1/8" thick end panels with 2 1/2" high solid oak arched edge banding at the top and bottom of the end panels with horizontal center slat and 5" wide vertical slats, 2" flat end posts tapered on 2 sides from the bottom of the panel to 1 1/2" at the floor, 1 1/4" thick HPL work surface with 1 3/4" wide oak edge banding	3298.00
PS-3148-O-FPSCA	Carrel work station adder in oak 31" deep x 48 1/2" wide x 48" high, 1 1/8" thick intermediate panel with arched detailing at the top and bottom of the panel, 2" flat end posts tapered on 2 sides from the bottom of the panel to 1 1/2" at the floor, 1 1/4" thick HPL work surface with 1 3/4" thick oak edge banding	2715.00
PS-3136-O-FPDF	Elevated Panel Carrel work station, double faced, starter in oak 61" deep x 38" wide x 48" high, 1 1/8" thick end panels with 2 1/2" high solid oak arched edge banding at the top and bottom of the end panels with horizontal center slat and 5" wide vertical slats, 2" flat end posts tapered from the bottom of the panel to 1 1/2" at the floor, 2 each 1 1/4" thick HPL work surfaces with 1 3/4" thick oak edge banding	4876.00
PS-3136-O-FPDFA	Carrel work station, double faced, adder in oak 61" deep x 36 1/2" wide x 48" high, 1 1/8" thick intermediate panels with arched detailing at the top and bottom of the panel, 2" flat end posts tapered from the bottom of the to 1 1/2" at the floor, 2 each 1 1/4" thick HPL work surfaces with 1 3/4" thick oak edge banding	3954.00



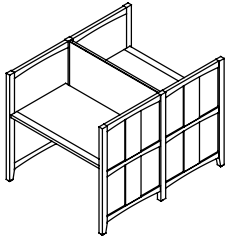

# Park Avenue

## FULL PANEL CARRELS WITH SQUARE TAPERED LEGS

MODEL NUMBER	DESCRIPTION	LIST PRICE
PS-3148-O-FPDF	Elevated Panel Carrel work station, double faced, starter in oak 61" deep x 50" wide x 48" high, 1 1/8" thick end panels with 2 1/2" high solid oak arched edge banding at the top and bottom of the end panels with horizontal center slat and 5" wide vertical slats, 2" flat end posts tapered from the bottom of the panel to 1 1/2" at the floor, 2 each 1 1/4" thick HPL work surfaces with 1 3/4" thick oak edge banding	5175.00
PS-3148-O-FPDFA	Carrel work station, double faced, adder in oak 61" deep x 48 1/2" wide x 48" high, 1 1/8" thick intermediate panels with arched detailing at the top and bottom of the panels, 2" flat end posts tapered to 1 1/2" at the bottom, 1 1/4" thick HPL work surfaces with 1 3/4" thick oak edge banding	4285.00
SHELF	For each book shelf at 145.00.	
SUFFIX-M	For maple study carrels change suffix O to M and add 7 percent.	
SUFFIX-C	For cherry study carrels change suffix O to C and add 7 percent.	



# Park Avenue

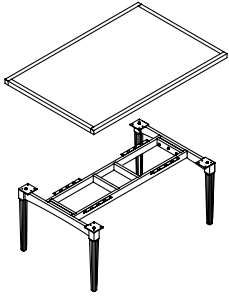

## READING TABLES WITH ROUND TAPERED LEGS

MODEL NUMBER	DESCRIPTION	LIST PRICE
PR-3648-O-T	Table 36" deep x 48" wide in oak, HPL top 1 1/4" thick with 1 3/4" W x 1 5/8" H drop edge banding, 3" arched aprons at each end, 2 3/4" solid oak round legs tapered to 1 1/2" at the bottom with metal leg plates, ladder keel for structural support	2280.00
PR-3060-O-T	Table 30" deep x 60" wide in oak, HPL top 1 1/4" thick with 1 3/4" W x 1 5/8" H drop edge banding, 3" arched aprons at each end, 2 3/4" solid oak round legs tapered to 1 1/2" at the bottom with metal leg plates, ladder keel for structural support	2433.00
PR-3660-O-T	Table 36" deep x 60" wide in oak, HPL top 1 1/4" thick with 1 3/4" W x 1 5/8" H drop edge banding, 3" arched aprons at each end, 2 3/4" solid oak round legs tapered to 1 1/2" at the bottom with metal leg plates, ladder keel for structural support	2493.00
PR-3672-O-T	Table 36" deep x 72" wide in oak, HPL top 1 1/4" thick with 1 3/4" W x 1 5/8" H drop edge banding, 3" arched aprons at each end, 2 3/4" solid oak round legs tapered to 1 1/2" at the bottom with metal leg plates, ladder keel for structural support	2726.00
PR-3696-O-T	Table 36" deep x 96" wide in oak, HPL top 1 1/4" thick with 1 3/4" W x 1 5/8" H drop edge banding, 3" arched aprons at each end, 2 3/4" solid oak round legs tapered to 1 1/2" at the bottom with metal leg plates, ladder keel for structural support	3134.00
PR-4272-O-T	Table 42" deep x 72" wide in oak, HPL top 1 1/4" thick with 1 3/4" W x 1 5/8" H drop edge banding, 3" arched aprons at each end, 2 3/4" solid oak round legs tapered to 1 1/2" at the bottom with metal leg plates, ladder keel for structural support	2827.00
PR-4296-O-T	Table 42" deep x 96" wide in oak, HPL top 1 1/4" thick with 1 3/4" W x 1 5/8" H drop edge banding, 3" arched aprons at each end, 2 3/4" solid oak round legs tapered to 1 1/2" at the bottom with metal leg plates, ladder keel for structural support	3260.00
PR-4872-O-T	Table 48" deep x 72" wide in oak, HPL top 1 1/4" thick with 1 3/4" W x 1 5/8" H drop edge banding, 3" arched aprons at each end, 2 3/4" solid oak round legs tapered to 1 1/2" at the bottom with metal leg plates, ladder keel for structural support	2929.00



# Park Avenue

## READING TABLES WITH ROUND TAPERED LEGS

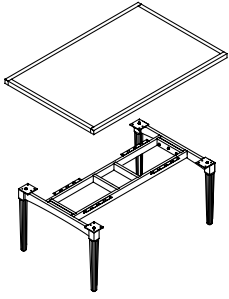

MODEL NUMBER	DESCRIPTION	LIST PRICE
PR-4896-O-T	Table 48" deep x 96" wide in oak, HPL top 1 1/4" thick with 1 3/4" W x 1 5/8" H drop edge banding, 3" arched aprons at each end, 2 3/4" solid oak round legs tapered to 1 1/2" at the bottom with metal leg plates, ladder keel for structural support	3352.00
PR-4242-O-T	Table 42" square in oak, HPL top 1 1/4" thick with 1 3/4" W x 1 5/8" H drop edge banding. 3" arched aprons at each end, 2 3/4" solid oak round legs tapered to 1 1/2" at the bottom with metal leg plates, ladder keel for structural support	2131.00
PR-4848-O-T	Table 48" square in oak, HPL top 1 1/4" thick with 1 3/4" W x 1 5/8" H drop edge banding, 3" arched aprons at each end, 2 3/4" solid oak round legs tapered to 1 1/2" at the bottom with metal leg plates, ladder keel for structural support	2160.00
PR-42R-O-T	Table 42" round in oak, HPL top 1 1/4" thick with 1 3/4" W x 1 5/8" H drop edge banding, 3" arched aprons, 2 3/4" solid oak round legs tapered to 1 1/2" at the bottom with metal leg plates	2423.00
PR-48R-O-T	Table 48" round in oak, HPL top 1 1/4" thick with 1 3/4" W x 1 5/8" H drop edge banding, 3" arched aprons, 2 3/4" solid oak round legs tapered to 1 1/2" at the bottom with metal leg plates	2648.00
PR-60R-O-T	Table 60" round in oak, HPL top 1 1/4" thick with 1 3/4" W x 1 5/8" H drop edge banding, 3" arched aprons, 2 3/4" solid oak round legs tapered to 1 1/2" at the bottom with metal leg plates	2853.00
SUFFIX -M	For maple change the suffix O to M and add 7 percent.	
SUFFIX -C	For cherry change the suffix O to C and add 20 percent.	



# Park Avenue

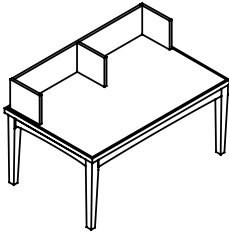

## IT TABLES WITH MONITOR RACKS AND ROUND TAPERED LEGS

MODEL NUMBER	DESCRIPTION	LIST PRICE
PR-3036-O-IT	Information technology table 30" deep x 36" wide in oak, HPL top 1 1/4" T with 1 3/4" W x 1 5/8" H drop edge banding, 3" arched aprons at the ends, 2 3/4" solid oak round legs tapered to 1 1/2" at the bottom, metal leg plates and ladder keel, 10" high monitor rack at the back of the table and extending forward 10" at each end	2474.00
PR-3048-O-IT	Information technology table 30" deep x 48" wide in oak, HPL top 1 1/4" T with 1 3/4" W x 1 5/8" H drop edge banding, 3" arched aprons at the ends, 2 3/4" solid oak round legs tapered to 1 1/2" at the bottom, metal leg plates and ladder keel, 10" high monitor rack at the back of the table and extending forward 10" at each end	2567.00
PR-3060-O-IT	Information technology table 30" deep x 60" wide in oak, HPL top 1 1/4" T with 1 3/4" W x 1 5/8" H drop edge banding, 3" arched aprons at the ends, 2 3/4" solid oak round legs tapered to 1 1/2" at the bottom, metal leg plates and ladder keel, 10" high monitor rack at the back of the table and extending forward 10" at each end	2777.00
PR-3072-O-IT	Information technology table 30" deep x 72" wide in oak, HPL top 1 1/4" T with 1 3/4" W x 1 5/8" H drop edge banding, 3" arched aprons at the ends, 2 3/4" solid oak round legs tapered to 1 1/2" at the bottom, metal leg plates and ladder keel, 10" high monitor rack at the back of the table and extending forward 10" at each end	3041.00
PR-3072-O-IT2	Information technology table 30" deep x 72" wide in oak, HPL top 1 1/4" T with 1 3/4" W x 1 5/8" H drop edge banding, 3" arched aprons at the ends, 2 3/4" solid oak round legs tapered to 1 1/2" at the bottom, metal leg plates and ladder keel, 10" high monitor rack at the back of the table and extending forward 10" at each end and the center	3094.00
PR-3096-O-IT2	Information technology table 30" deep x 96" wide in oak, HPL top 1 1/4" T with 1 3/4" W x 1 5/8" H drop edge banding, 3" arched aprons at the ends, 2 3/4" solid oak round legs tapered to 1 1/2" at the bottom, metal leg plates and ladder keel, 10" high monitor rack at the back of the table and extending forward 10" at each end and the center	3583.00
PR-3096-O-IT3	Information technology table 30" deep x 96" wide in oak, HPL top 1 1/4" T with 1 3/4" W x 1 5/8" H drop edge banding, 3" arched aprons at the ends, 2 3/4" solid oak round legs tapered to 1 1/2" at the bottom, metal leg plates and ladder keel, 10" high monitor rack at the back of the table and extending forward 10" at each end and 2 center points dividing the table into 3 equal work spaces	3636.00



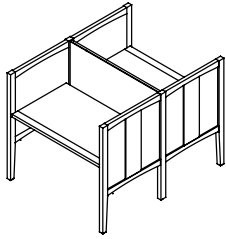

# Park Avenue

## POST AND PANEL CARRELS WITH ROUND TAPERED LEGS

MODEL NUMBER	DESCRIPTION	LIST PRICE
PR-3136-O-PPSC	Elevated Panel Carrel work station starter in oak 31" deep x 38" wide x 48" high, 1 1/8" thick end panels with 2 1/2" high solid oak arched edge banding at the top and bottom of the panel with 5" wide center slat, 2" round posts tapered from the bottom of the panel to 1 1/2" at the floor, 1 1/4" thick HPL work surface with 1 3/4" thick oak edge banding	2455.00
PR-3136-O-PPSCA	Carrel work station adder in oak 31" deep x 36 1/2" wide x 48" high, 1 1/8" thick intermediate panel with arched detailing at the top and bottom of the panel, 2" round posts tapered from the bottom of the panel to 1 1/2" at the floor, 1 1/4" thick HPL work surface with 1 3/4" thick edge oak banding	1899.00
PR-3150-O-PPSC	Elevated Panel Carrel work station starter in oak 31" deep x 50" wide x 48" high, 1 1/8" thick end panels with 2 1/2" high solid oak arched edge banding at the top and bottom of the panel with 5" wide center slat, 2" round posts tapered from the bottom of the panel to 1 1/2" at the floor, 1 1/4" thick HPL work surface with 1 3/4" thick oak edge banding	2592.00
PR-3148-O-PPSCA	Carrel work station adder in oak 31" deep x 48 1/2" wide x 48" high, 1 1/8" thick intermediate panel with arched detailing at the top and bottom of the panel, 2" round posts tapered from the bottom of the panel to 1 1/2" at the floor, 1 1/4" thick HPL work surface with 1 3/4" thick oak edge banding	2039.00
PR-3136-O-PPDF	Elevated Panel Carrel work station, double faced, starter in oak 61" deep x 38" wide x 48" high, 1 1/8" thick end panels with 2 1/2" high solid oak arched edge banding at top and bottom of panels with 5" wide vertical slat, 2" round posts tapered from the bottom of the panel to 1 1/2" at the floor, 2 each 1 1/4" thick HPL work surfaces with 1 3/4" thick edge banding	4066.00
PR-3136-O-PPDFA	Carrel work station, double faced, adder in oak 61" deep x 36 1/2" wide x 48" high, 1 1/8" thick intermediate panels with arched detailing at the top and bottom of the panel, 2" round posts tapered from the bottom of the panel to 1 1/2" at the floor, 2 each 1 1/4" thick HPL work surfaces with 1 3/4" thick oak edge banding drop	3413.00



# Park Avenue

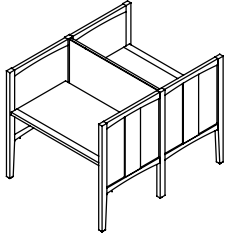

## POST AND PANEL CARRELS WITH ROUND TAPERED LEGS

MODEL NUMBER	DESCRIPTION	LIST PRICE
PR-3148-O-PPDF	Elevated Panel Carrel work station, double faced, starter in oak 61" deep x 50" wide x 48" high, 1 1/8" thick end panels with 2 1/2" high solid oak arched edge banding at top and bottom of panels with 5" wide vertical slat, 2" round posts tapered from the bottom of the panel to 1 1/2" at the floor, 2 each 1 1/4" thick HPL work surfaces with 1 3/4" thick edge oak banding	4859.00
PR-3148-O-PPDFA	Carrel work station, double faced, adder in oak 61" deep x 48 1/2" wide x 48" high, 1 1/8" thick intermediate panels with arched detailing at the top and bottom of the panel at top and bottom of panels, 2" round posts tapered from the bottom of the panel to 1 1/2" at the floor, 2 each 1 1/4" thick HPL work surfaces with 1 3/4" thick edge oak banding	4003.00
SHELF	For each book shelf at 145.00.	
SUFFIX -M	For maple change the suffix O to M and add 7 percent.	
SUFFIX -C	For cherry change the suffix O to C and add 20 percent.	



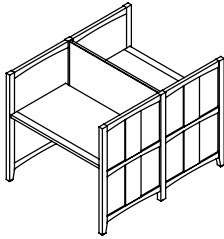

# Park Avenue

## FULL PANEL CARRELS WITH ROUND TAPERED LEGS

MODEL NUMBER	DESCRIPTION	LIST PRICE
PR-3136-O-FPSC	Elevated Panel Carrel work station starter in oak 31" deep x 38" wide x 48" high, 1 1/8" thick end panels with 2 1/2" high solid oak arched edge banding at the top and bottom of the end panels with horizontal center slat and 5" wide vertical slats, 2" round end posts tapered from the bottom of the panel to 1 1/2" at the floor, 1 1/4" thick HPL work surface with 1 3/4" wide oak edge banding	2738.00
PR-3136-O-FPSCA	Carrel work station adder in oak 31" deep x 36 1/2" wide x 48" high, 1 1/8" thick intermediate panel with arched detailing at the top and bottom of the panel, 2" round posts tapered from the bottom of the panel to 1 1/2" at the floor, 1 1/4" thick HPL work surface with 1 3/4" thick oak edge banding	2213.00
PR-3150-O-FPSC	Elevated Panel Carrel work station starter in oak 31" deep x 50" wide x 48" high, 1 1/8" thick end panels with 2 1/2" high solid oak arched edge banding at the top and bottom of the end panels with horizontal center slat and 5" wide vertical slats, 2" round end posts tapered from the bottom of the panel to 1 1/2" at the floor, 1 1/4" thick HPL work surface with 1 3/4" wide oak edge banding	2905.00
PR-3148-O-FPSCA	Carrel work station adder in oak 31" deep x 48 1/2" wide x 48" high, 1 1/8" thick intermediate panel with arched detailing at the top and bottom of the panel, 2" round posts tapered from the bottom of the panel to 1 1/2" at the floor, 1 1/4" thick HPL work surface with 1 3/4" thick oak edge banding	2379.00
PR-3136-O-FPDF	Elevated Panel Carrel work station, double faced, starter in oak 61" deep x 38" wide x 48" high, 1 1/8" thick end panels with 2 1/2" high solid oak arched edge banding at the top and bottom of the end panels with horizontal center slat and 5" wide vertical slats, 2" round posts tapered from the bottom of the panel to 1 1/2" at the floor, 2 each 1 1/4" thick work surfaces with 1 3/4" thick oak edge banding	4552.00
PR-3136-O-FPDFA	Carrel work station, double faced, adder in oak 61" deep x 36 1/2" wide x 48" high, 1 1/8" thick intermediate panels with arched detailing at the top and bottom of the panel, 2" round posts tapered from the bottom of the to 1 1/2" at the floor, 2 each 1 1/4" thick HPL work surfaces with 1 3/4" thick oak edge banding	3696.00



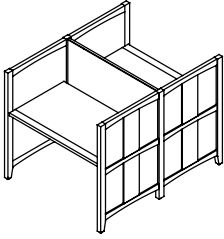

# Park Avenue

## FULL PANEL CARRELS WITH ROUND TAPERED LEGS

MODEL NUMBER	DESCRIPTION	LIST PRICE
PR-3148-O-FPDF	Elevated Panel Carrel work station, double faced, starter in oak 61" deep x 50" wide x 48" high, 1 1/8" thick end panels with 2 1/2" high solid oak arched edge banding at the top and bottom of the end panel with horizontal slat and 5" wide vertical slats, 2" round posts tapered from the bottom of the panel to 1 1/2" at the floor, 2 each	4859.00
	1 1/4" thick HPL work surfaces with 1 3/4" thick oak edge banding	
PR-3148-O-FPDFA	Carrel work station, double faced, adder in oak 61" deep x 48 1/2" wide x 48" high, 1 1/8" thick intermediate panels with arched detailing at the top and bottom of the panel, 2" round posts tapered to 1 1/2" at the bottom, 1 1/4" thick HPL work surfaces with 1 3/4" thick oak edge banding	4003.00
SHELF	For each book shelf at 145.00.	
SUFFIX -M	For maple change the suffix O to M and add 7 percent.	
SUFFIX -C	For cherry change the suffix O to C and add 20 percent.	

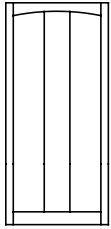

# Park Avenue

## END PANELS IN OAK

MODEL NUMBER	DESCRIPTION	LIST PRICE
P-4412-DF-O	End panel 44" H x 12" W, 1 1/8" T with 2 1/2" solid oak arched edge banding at top and bottom edges with 2" T edge banding on vertical edges, 5" W center pilaster	583.00
P-4413-DF-O	End panel 44" H x 13" W, 1 1/8" T with 2 1/2" solid oak arched edge banding at top and bottom edges with 2" T edge banding on vertical edges, 5" W center pilaster	621.00
P-4414-DF-O	End panel 44" H x 14" W, 1 1/8" T with 2 1/2" solid oak arched edge banding at top and bottom edges with 2" T edge banding on vertical edges, 5" W center pilaster	659.00
P-4416-DF-O	End panel 44" H x 16" W, 1 1/8" T with 2 1/2" solid oak arched edge banding at top and bottom edges with 2" T edge banding on vertical edges, 5" W center pilaster	696.00
P-4418-DF-O	End panel 44" H x 18" W, 1 1/8" T with 2 1/2" solid oak arched edge banding at top and bottom edges with 2" T edge banding on vertical edges, 5" W center pilaster	732.00
P-4420-DF-O	End panel 44" H x 20" W, 1 1/8" T with 2 1/2" solid oak arched edge banding at top and bottom edges with 2" T edge banding on vertical edges, 5" W center pilaster	780.00
P-4422-DF-O	End panel 44" H x 22" W, 1 1/8" T with 2 1/2" solid oak arched edge banding at top and bottom edges with 2" T edge banding on vertical edges, 5" W center pilaster	830.00
P-4424-DF-O	End panel 44" H x 24" W, 1 1/8" T with 2 1/2" solid oak arched edge banding at top and bottom edges with 2" T edge banding on vertical edges, 5" W center pilaster	855.00
P-4425-DF-O	End panel 44" H x 25" W, 1 1/8" T with 2 1/2" solid oak arched edge banding at top and bottom edges with 2" T edge banding on vertical edges, 5" W center pilaster	891.00
P-4428-DF-O	End panel 44" H x 28" W, 1 1/8" T with 2 1/2" solid oak arched edge banding at top and bottom edges with 2" T edge banding on vertical edges, 5" W center pilaster	928.00
P-4432-DF-O	End panel 44" H x 32" W, 1 1/8" T with 2 1/2" solid oak arched edge banding at top and bottom edges with 2" T edge banding on vertical edges, 5" W center pilaster	914.00
P-5012-DF-O	End panel 50" H x 12" W, 1 1/8" T with 2 1/2" solid oak arched edge banding at top and bottom edges with 2" T edge banding on vertical edges, 5" W center pilaster	624.00



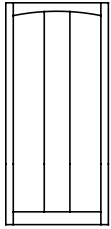

# Park Avenue

## END PANELS IN OAK

MODEL NUMBER	DESCRIPTION	LIST PRICE
P-5013-DF-O	End panel 50" H x 13" W, 1 1/8" T with 2 1/2" solid oak arched edge banding at top and bottom edges with 2" T edge banding on vertical edges, 5" W center pilaster	639.00
P-5014-DF-O	End panel 50" H x 14" W, 1 1/8" T with 2 1/2" solid oak arched edge banding at top and bottom edges with 2" T edge banding on vertical edges, 5" W center pilaster	654.00
P-5016-DF-O	End panel 50" H x 16" W, 1 1/8" T with 2 1/2" solid oak arched edge banding at top and bottom edges with 2" T edge banding on vertical edges, 5" W center pilaster	685.00
P-5018-DF-O	End panel 50" H x 18" W, 1 1/8" T with 2 1/2" solid oak arched edge banding at top and bottom edges with 2" T edge banding on vertical edges, 5" W center pilaster	748.00
P-5020-DF-O	End panel 50" H x 20" W, 1 1/8" T with 2 1/2" solid oak arched edge banding at top and bottom edges with 2" T edge banding on vertical edges, 5" W center pilaster	820.00
P-5022-DF-O	End panel 50" H x 22" W, 1 1/8" T with 2 1/2" solid oak arched edge banding at top and bottom edges with 2" T edge banding on vertical edges, 5" W center pilaster	842.00
P-5024-DF-O	End panel 50" H x 24" W, 1 1/8" T with 2 1/2" solid oak arched edge banding at top and bottom edges with 2" T edge banding on vertical edges, 5" W center pilaster	866.00
P-5025-DF-O	End panel 50" H x 25" W, 1 1/8" T with 2 1/2" solid oak arched edge banding at top and bottom edges with 2" T edge banding on vertical edges, 5" W center pilaster	901.00
P-5028-DF-O	End panel 50" H x 28" W, 1 1/8" T with 2 1/2" solid oak arched edge banding at top and bottom edges with 2" T edge banding on vertical edges, 5" W center pilaster	944.00
P-5032-DF-O	End panel 50" H x 32" W, 1 1/8" T with 2 1/2" solid oak arched edge banding at top and bottom edges with 2" T edge banding on vertical edges, 5" W center pilaster	1094.00
P-6612-DF-O	End panel 66" H x 12" W, 1 1/8" T with 2 1/2" solid oak arched edge banding at top and bottom edges with 2" T edge banding on vertical edges, 5" W center pilaster	707.00
P-6613-DF-O	End panel 66" H x 13" W, 1 1/8" T with 2 1/2" solid oak arched edge banding at top and bottom edges with 2" T edge banding on vertical edges, 5" W center pilaster	722.00



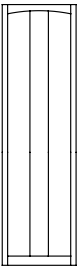

# Park Avenue

## END PANELS IN OAK

MODEL NUMBER	DESCRIPTION	LIST PRICE
P-6614-DF-O	End panel 66" H x 14" W, 1 1/8" T with 2 1/2" solid oak arched edge banding at top and bottom edges with 2" T edge banding on vertical edges, 5" W center pilaster	739.00
P-6616-DF-O	End panel 66" H x 16" W, 1 1/8" T with 2 1/2" solid oak arched edge banding at top and bottom edges with 2" T edge banding on vertical edges, 5" W center pilaster	763.00
P-6618-DF-O	End panel 66" H x 18" W, 1 1/8" T with 2 1/2" solid oak arched edge banding at top and bottom edges with 2" T edge banding on vertical edges, 5" W center pilaster	817.00
P-6620-DF-O	End panel 66" H x 20" W, 1 1/8" T with 2 1/2" solid oak arched edge banding at top and bottom edges with 2" T edge banding on vertical edges, 5" W center pilaster	935.00
P-6622-DF-O	End panel 66" H x 22" W, 1 1/8" T with 2 1/2" solid oak arched edge banding at top and bottom edges with 2" T edge banding on vertical edges, 5" W center pilaster	970.00
P-6624-DF-O	End panel 66" H x 24" W, 1 1/8" T with 2 1/2" solid oak arched edge banding at top and bottom edges with 2" T edge banding on vertical edges, 5" W center pilaster	1016.00
P-6625-DF-O	End panel 66" H x 25" W, 1 1/8" T with 2 1/2" solid oak arched edge banding at top and bottom edges with 2" T edge banding on vertical edges, 5" W center pilaster	1038.00
P-6628-DF-O	End panel 66" H x 28" W, 1 1/8" T with 2 1/2" solid oak arched edge banding at top and bottom edges with 2" T edge banding on vertical edges, 5" W center pilaster	1073.00
P-6632-DF-O	End panel 66" H x 32" W, 1 1/8" T with 2 1/2" solid oak arched edge banding at top and bottom edges with 2" T edge banding on vertical edges, 5" W center pilaster	1119.00
P-8412-DF-O	End panel 84" H x 12" W, 1 1/8" T with 2 1/2" solid oak arched edge banding at top and bottom edges with 2" T edge banding on vertical edges, 5" W center pilaster	902.00
P-8413-DF-O	End panel 84" H x 13" W, 1 1/8" T with 2 1/2" solid oak arched edge banding at top and bottom edges with 2" T edge banding on vertical edges, 5" W center pilaster	916.00
P-8414-DF-O	End panel 84" H x 14" W, 1 1/8" T with 2 1/2" solid oak arched edge banding at top and bottom edges with 2" T edge banding on vertical edges, 5" W center pilaster	943.00



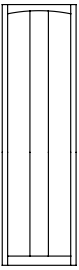

# Park Avenue

## END PANELS IN OAK

MODEL NUMBER	DESCRIPTION	LIST PRICE
P-8416-DF-O	End panel 84" H x 16" W, 1 1/8" T with 2 1/2" solid oak arched edge banding at top and bottom edges with 2" T edge banding on vertical edges, 5" W center pilaster	969.00
P-8418-DF-O	End panel 84" H x 18" W, 1 1/8" T with 2 1/2" solid oak arched edge banding at top and bottom edges with 2" T edge banding on vertical edges, 5" W center pilaster	1084.00
P-8420-DF-O	End panel 84" H x 20" W, 1 1/8" T with 2 1/2" solid oak arched edge banding at top and bottom edges with 2" T edge banding on vertical edges, 5" W center pilaster	1195.00
P-8422-DF-O	End panel 84" H x 22" W, 1 1/8" T with 2 1/2" solid oak arched edge banding at top and bottom edges with 2" T edge banding on vertical edges, 5" W center pilaster	1252.00
P-8424-DF-O	End panel 84" H x 24" W, 1 1/8" T with 2 1/2" solid oak arched edge banding at top and bottom edges with 2" T edge banding on vertical edges, 5" W center pilaster	1311.00
P-8425-DF-O	End panel 84" H x 25" W, 1 1/8" T with 2 1/2" solid oak arched edge banding at top and bottom edges with 2" T edge banding on vertical edges, 5" W center pilaster	1332.00
P-8428-DF-O	End panel 84" H x 28" W, 1 1/8" T with 2 1/2" solid oak arched edge banding at top and bottom edges with 2" T edge banding on vertical edges, 5" W center pilaster	1366.00
P-8432-DF-O	End panel 84" H x 32" W, 1 1/8" T with 2 1/2" solid oak arched edge banding at top and bottom edges with 2" T edge banding on vertical edges, 5" W center pilaster	1398.00
P-9012-DF-O	End panel 90" H x 12" W, 1 1/8" T with 2 1/2" solid oak arched edge banding at top and bottom edges with 2" T edge banding on vertical edges, 5" W center pilaster	922.00
P-9013-DF-O	End panel 90" H x 13" W, 1 1/8" T with 2 1/2" solid oak arched edge banding at top and bottom edges with 2" T edge banding on vertical edges, 5" W center pilaster	942.00
P-9014-DF-O	End panel 90" H x 14" D, 1 1/8" T with 2 1/2" solid oak arched edge banding at top and bottom edges with 2" T edge banding on vertical edges, 5" W center pilaster	971.00
P-9016-DF-O	End panel 90" H x 16" D, 1 1/8" T with 2 1/2" solid oak arched edge banding at top and bottom edges with 2" T edge banding on vertical edges, 5" W center pilaster	1000.00



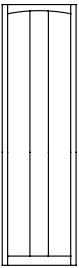

# Park Avenue

## END PANELS IN OAK

MODEL NUMBER	DESCRIPTION	LIST PRICE
P-9018-DF-O	End panel 90" H x 18" W, 1 1/8" T with 2 1/2" solid oak arched edge banding at top and bottom edges with 2" T edge banding on vertical edges, 5" W center pilaster	1206.00
P-9020-DF-O	End panel 90" H x 20" W, 1 1/8" T with 2 1/2" solid oak arched edge banding at top and bottom edges with 2" T edge banding on vertical edges, 5" W center pilaster	1264.00
P-9022-DF-O	End panel 90" H x 22" W, 1 1/8" T with 2 1/2" solid oak arched edge banding at top and bottom edges with 2" T edge banding on vertical edges, 5" W center pilaster	1310.00
P-9024-DF-O	End panel 90" H x 24" W, 1 1/8" T with 2 1/2" solid oak arched edge banding at top and bottom edges with 2" T edge banding on vertical edges, 5" W center pilaster	1345.00
P-9025-DF-O	End panel 90" H x 25" W, 1 1/8" T with 2 1/2" solid oak arched edge banding at top and bottom edges with 2" T edge banding on vertical edges, 5" W center pilaster	1367.00
P-9028-DF-O	End panel 90" H x 28" W, 1 1/8" T with 2 1/2" solid oak arched edge banding at top and bottom edges with 2" T edge banding on vertical edges, 5" W center pilaster	1402.00
P-9032-DF-O	End panel 90" H x 32" W, 1 1/8" T with 2 1/2" solid oak arched edge banding at top and bottom edges with 2" T edge banding on vertical edges, 5" W center pilaster	1425.00
SUFFIX-M	For maple change the suffix O to M and add 7 percent.	
SUFFIX-C	For cherry change the suffix O to C and add 20 percent.	



# Park Avenue

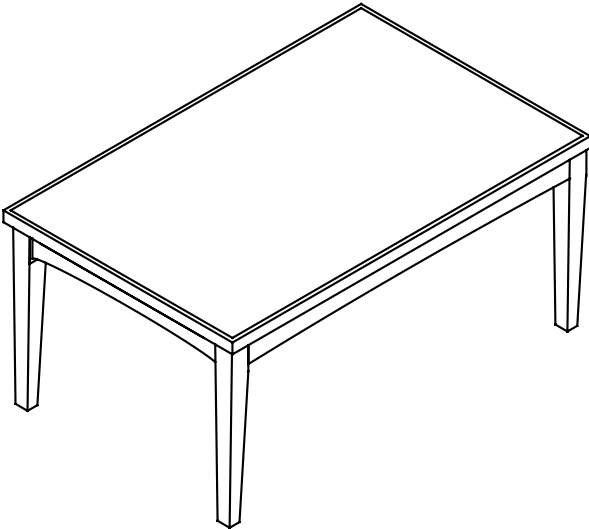

Reading table with square tapered legs and arched aprons

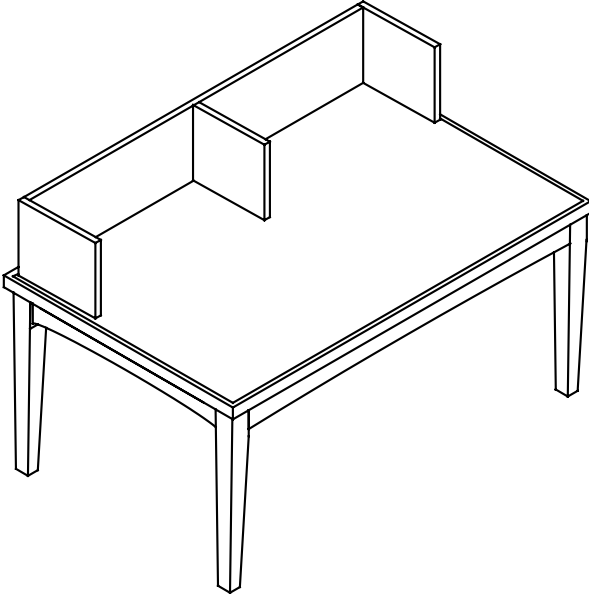

IT table with monitor racks, square tapered legs and arched aprons

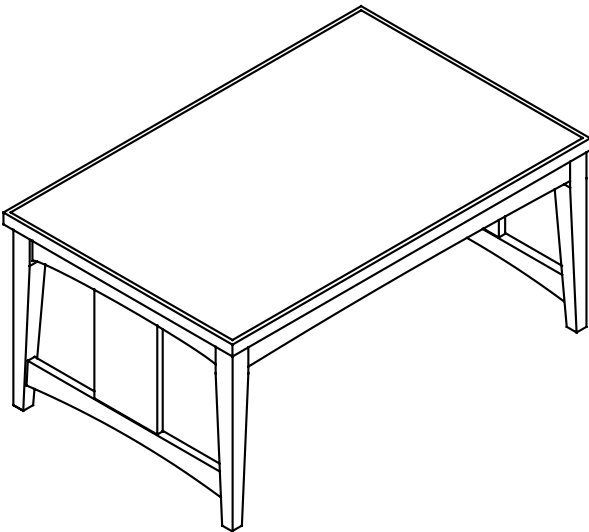

Reading table with square tapered legs, Sentinel ends and arched aprons

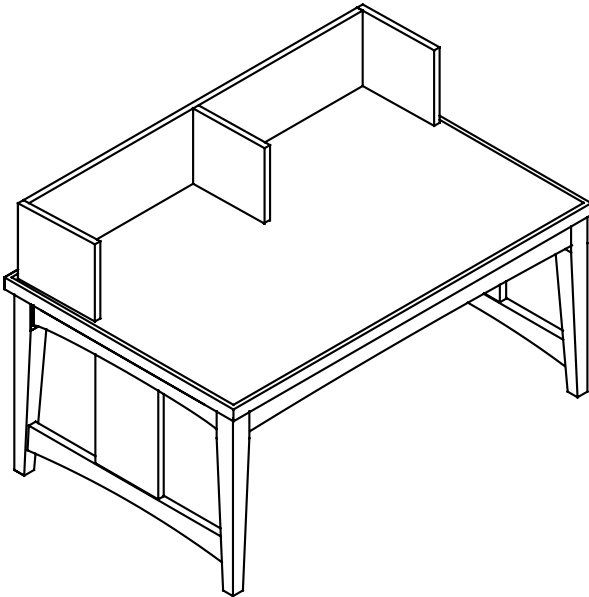

IT table with sentinel ends, monitor racks, square tapered legs and arched aprons



# Park Avenue

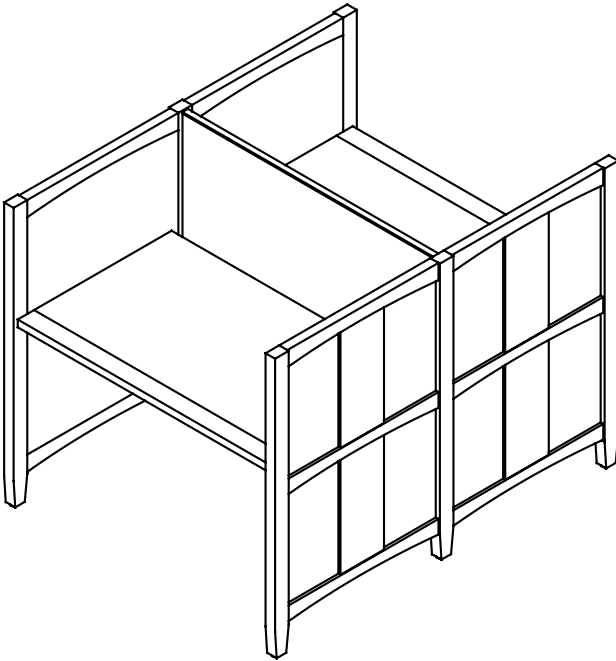

Full panel carrel with square tapered legs

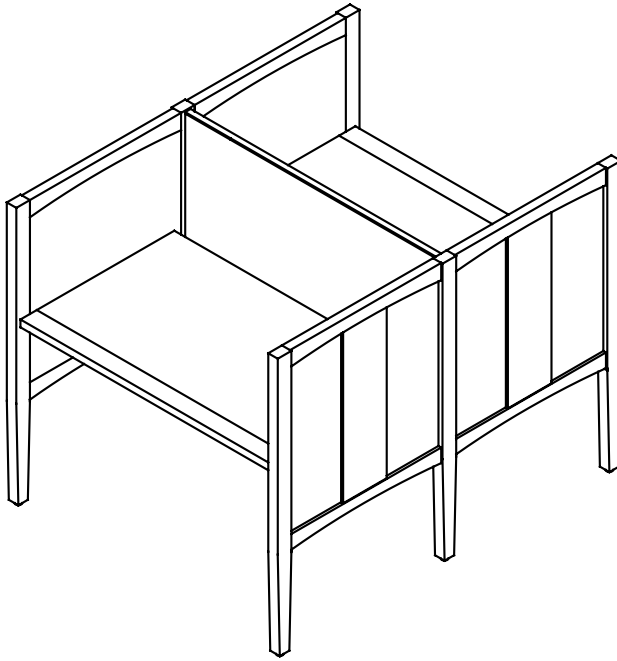

Post and panel carrel with square tapered legs

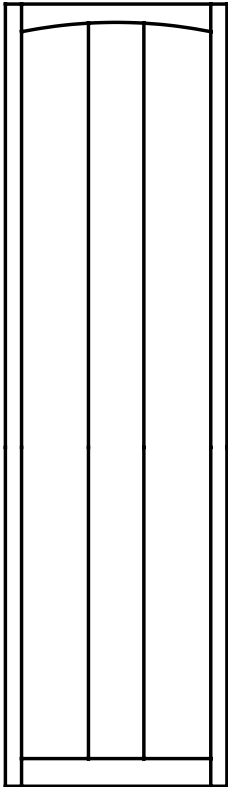

60" or above wood end panel

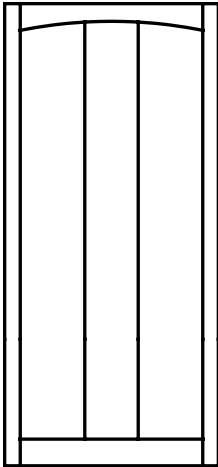

Wood end panel up to 48"



# Park Avenue

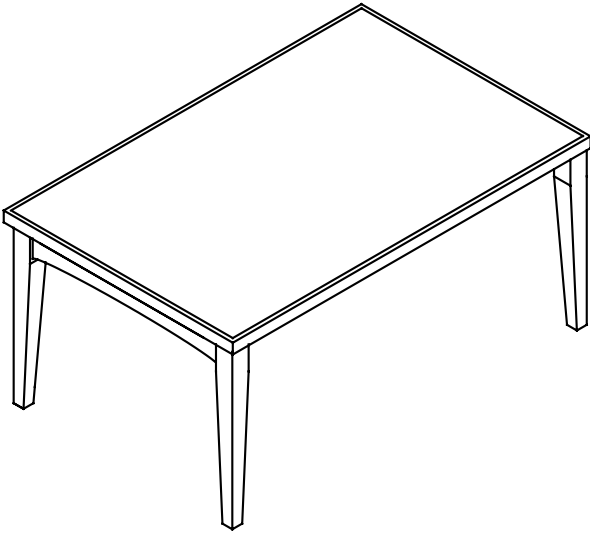

ADA Reading table with square tapered legs and arched aprons